



# **POINTED Victorianism**

F/W 2024

Sabrina Olmo



# POINTED VICTORIANISM F/W 24

inspiration chart

forme geometriche



fiore stilizzato



piccole dimensioni



elegante



pelle e plastica



traforazione laser

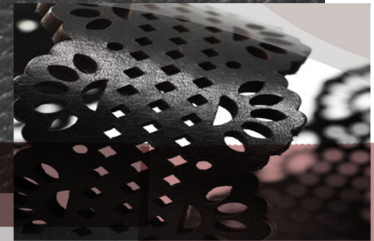

perline



puntinismo

POINTED VICTORIANISM F/W 24  
color chart

C 3  
Red Dahila  
19-1555 TPX

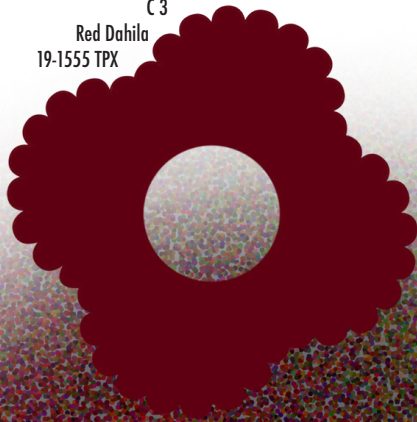

C 5  
withe



C 6  
Dandelion  
13-0758 TPX

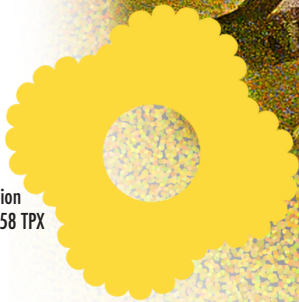

C 1  
black

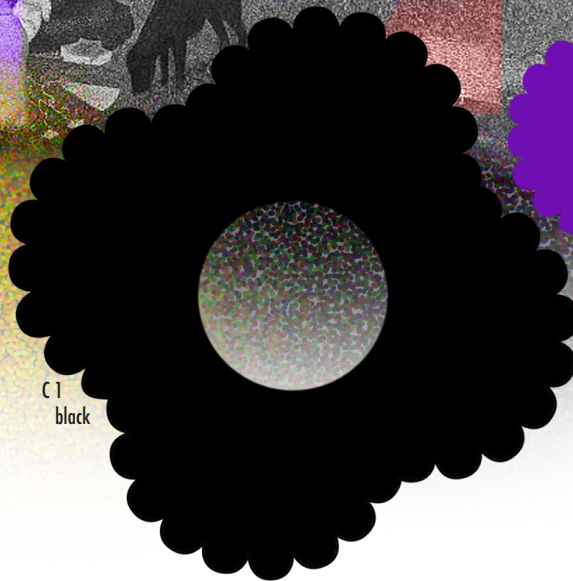

C 4  
Tillandsia Purple  
19-3638 TPX



# POINTED VICTORIANISM F/W 24

material chart



P 1  
PELLE DI VITELLO SPAZZOLATA

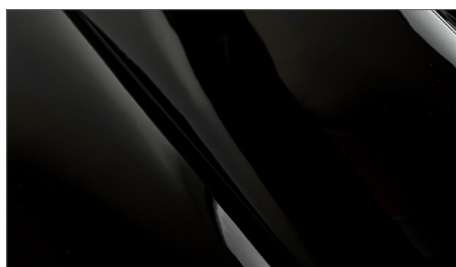
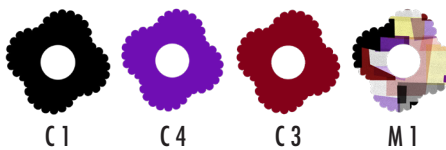

P 1  
PELLE DI VITELLO VERNICIATA

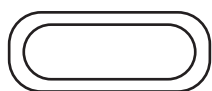

ANELLO DI METALLO RETTANGOLARE  
X2

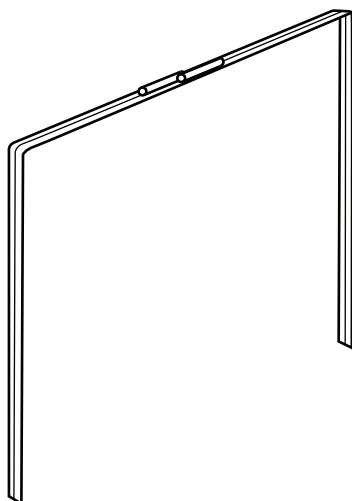

CHIUSURA IN METALLO POCLETTE

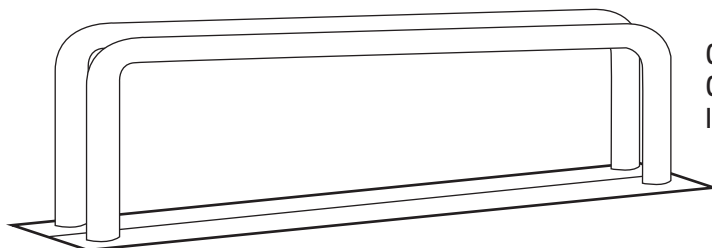

CHIUSURA IN METALLO  
CON CALAMITA E MANICI  
INCORPORATI

# POINTED VICTORIANISM F/W 24

manipulation chart

MP 1

STAMPA (all-over)

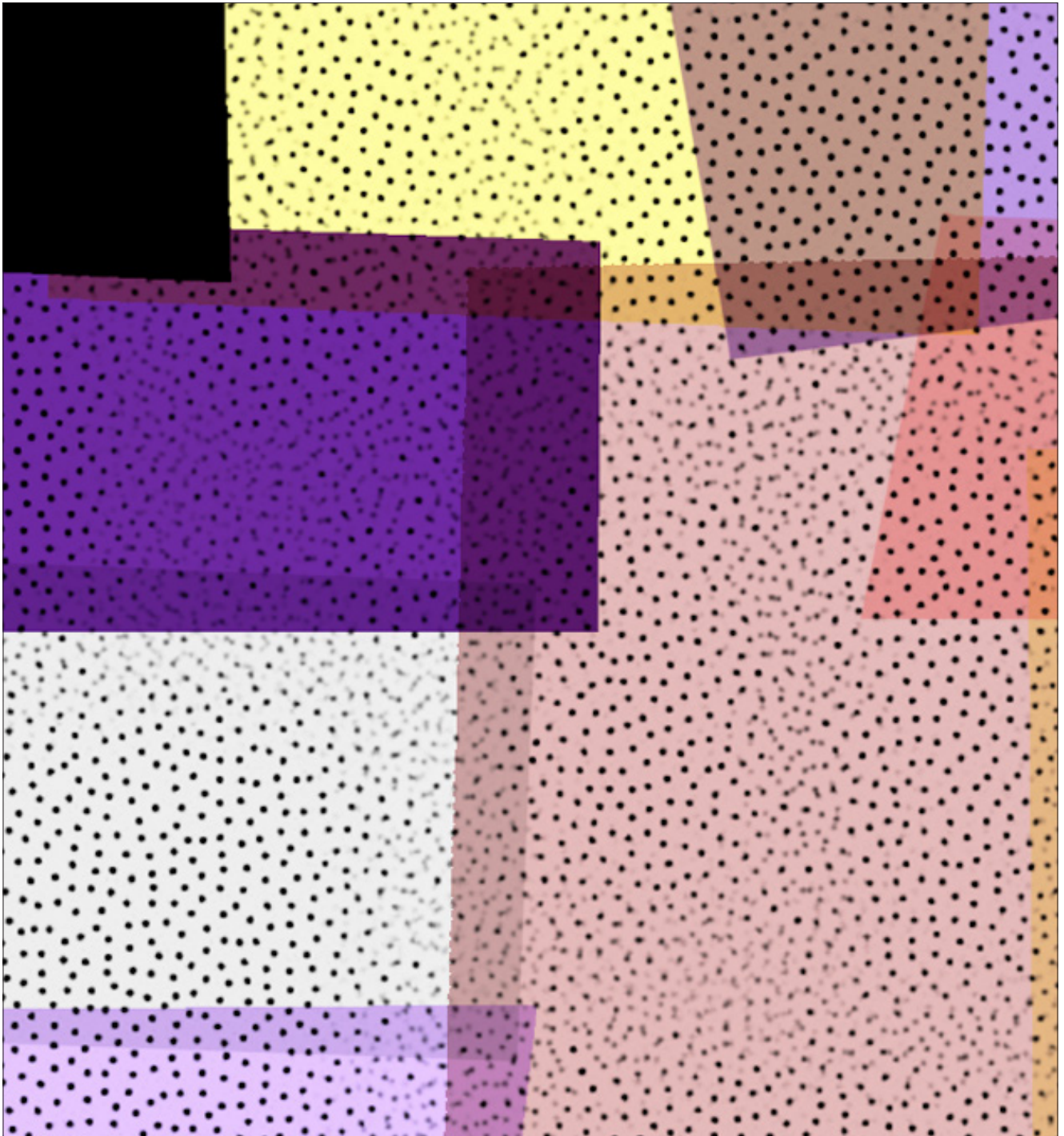

rappresentazione in dimensione reale

# POINTED VICTORIANISM F/W 24

manipulation chart

MP 1



STAMPA ALL OVER SU PELLE spazzolata, fantasia geometrica asimmetrica caratterizzata da effetto puntinato e colori accesi di collezione.



P 1



A 3



STAMPA 2 (all-over)

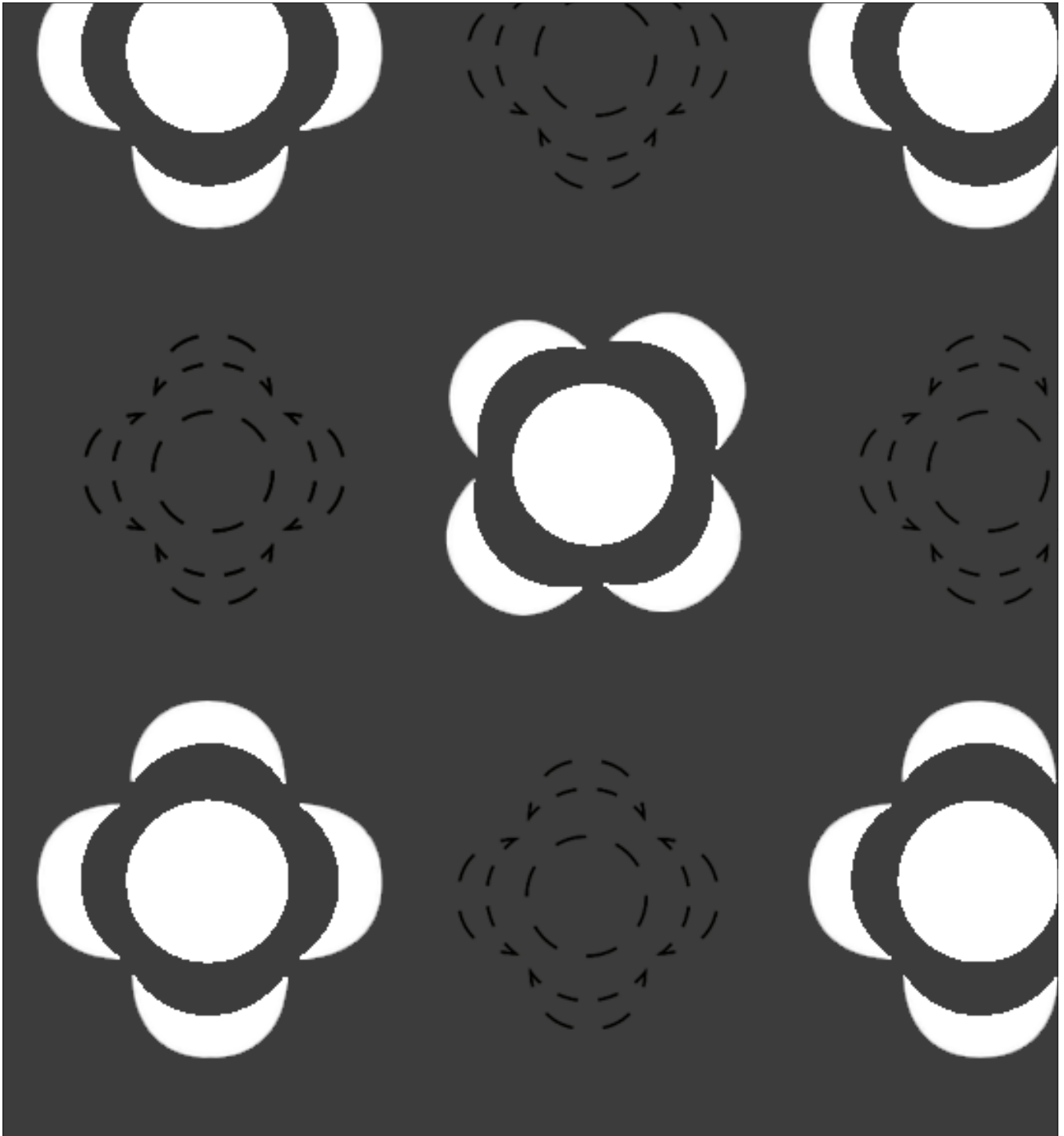

rappresentazione in dimensione reale

# POINTED VICTORIANISM F/W 24

manipulation chart

MP 2

disegno tecnico

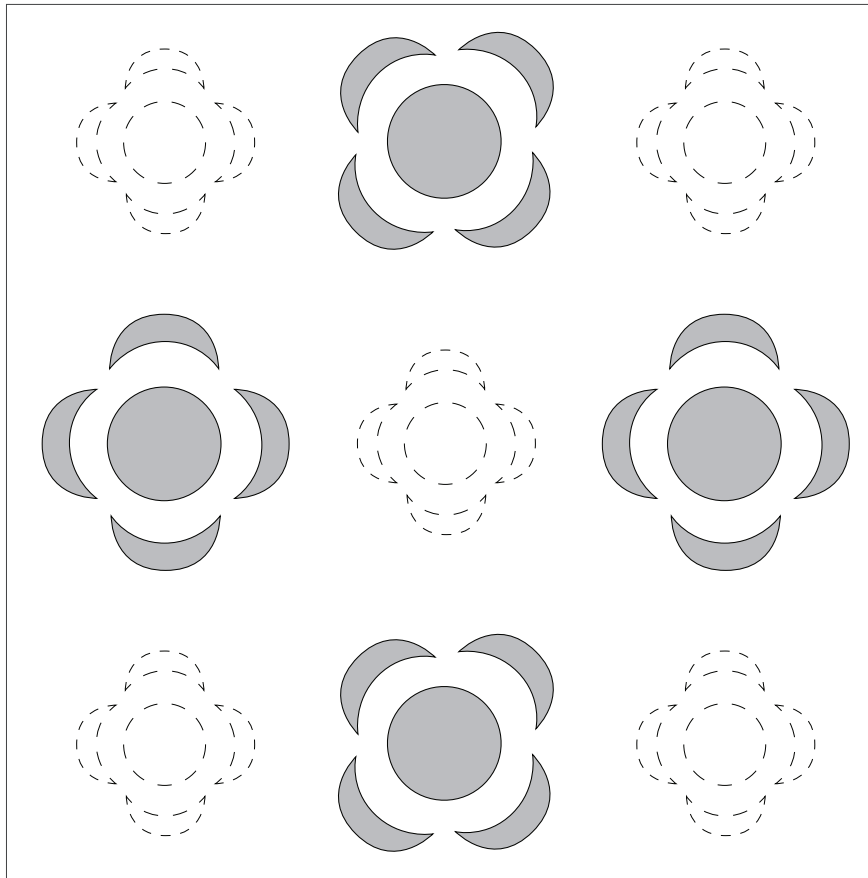

A4



A5



PELLE VERNICIATA TRAFORATA A LASER con motivo a forma di fiore stilizzato, arricchita da impunture decorative con la stessa forma di fiore in dimensioni ridotte leggermente e posizionate in maniera sfalsata e regolare.

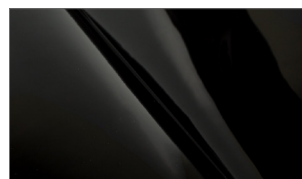

P1

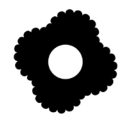

C1

POINTED VICTORIANISM F/W 24

illustration chart

A 1



POINTED VICTORIANISM F/W 24

illustration chart

A 2





# POINTED VICTORIANISM F/W 24

illustration chart

A 4



POINTED VICTORIANISM F/W 24

illustration chart

A 5



# POINTED VICTORIANISM F/W 24

technical chart

A 2

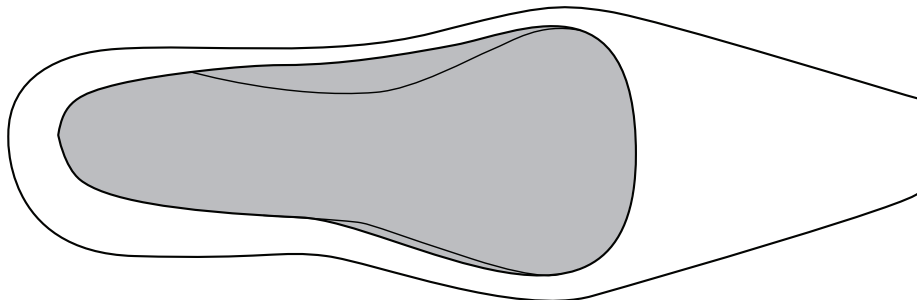
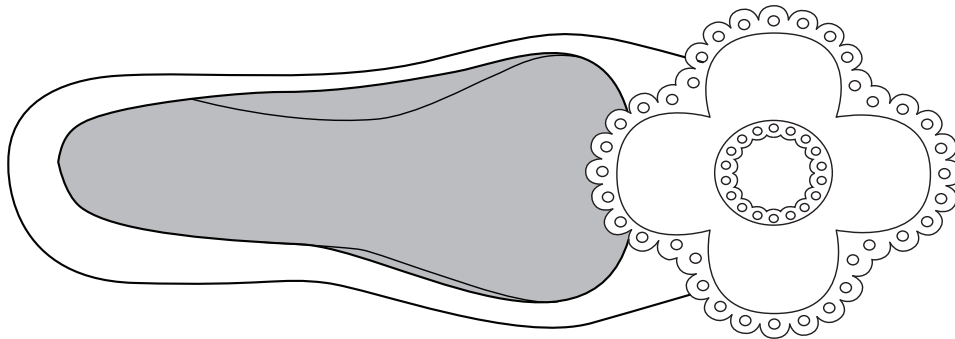
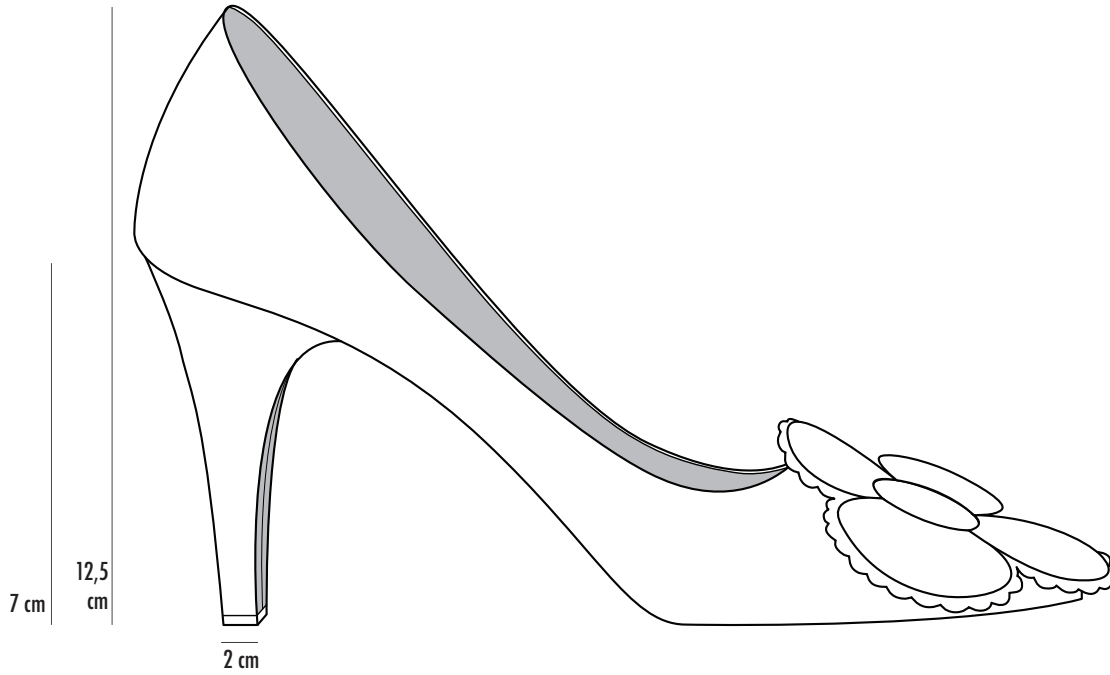

# POINTED VICTORIANISM F/W 24

technical chart

A 2

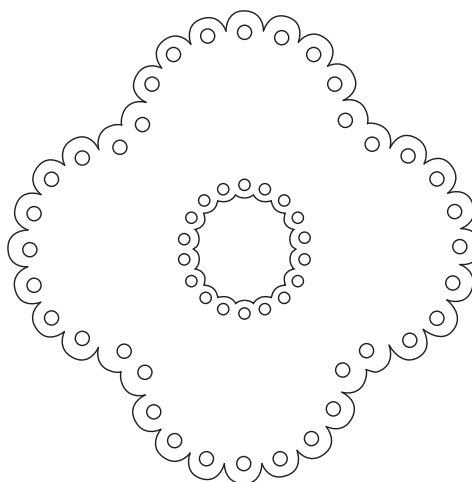
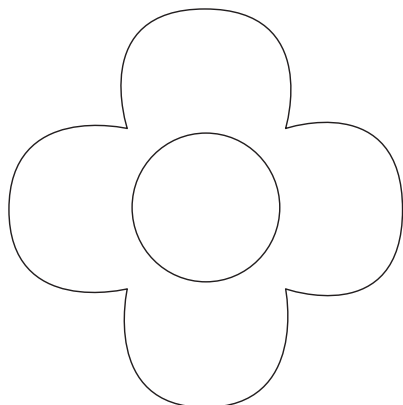

10 cm

P 1



## DESCRIZIONE:

Scarpa décolleté con tacco alto 7 centimetri, in pelle spazzolata. Arricchita da un fiore stilizzato di due strati di pelle traforata posizionato sulla punta quadrata della scarpa.



C1

C4

C3

A 2

varianti colori



# POINTED VICTORIANISM F/W 24

technical chart

53  
cm

27  
cm



30 cm

45 cm

15 cm

5 cm

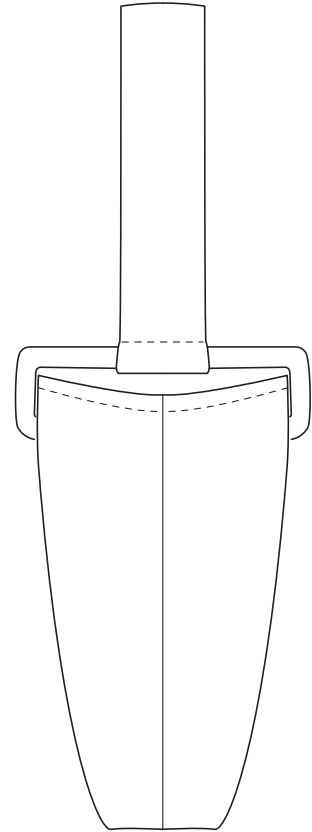

4 cm



MP 2

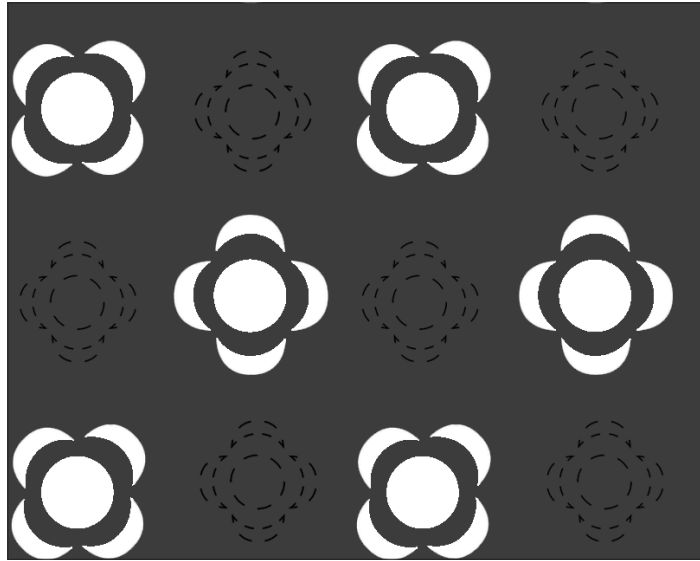

P 1

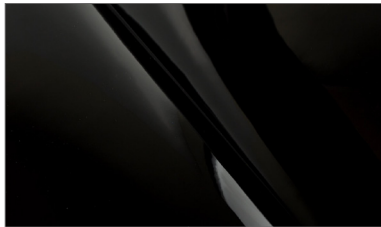

DESCRIZIONE:

Borsa senza chiusura di ampie dimensioni con un solo manico trattenuto da due anelli rettangolari di metallo, realizzata in pelle verniciata nera con fodera interna rossa, arricchita da traforatura e impuntura decorative.



C 1

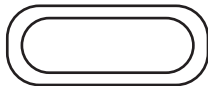

ANELLO DI METALLO RETTANGOLARE  
X2

A 6



# POINTED VICTORIANISM F/W 24/25

over view



# POINTED VICTORIANISM F/W 24

references



Moda primavera di Parigi, (1875), Unbekannt, [online] meisterdrucke.it, available at: <https://www.meisterdrucke.it/stampe-d-arte/Unbekannt/796274/Moda-primavera-di-Parigi%2C-1875.html> [20-01-2024]



Mary quant Logos, logolynx.com, [online] available at: <https://www.logolynx.com/topic/mary+quant> [20-01-2024]



Jean Shrimpton 1964, Photo David Bailey, [online] PLEASUREPHOTO, available at: <https://pleasurephoto.wordpress.com/2012/09/26/jean-shrimpton-1964-ph-david-bailey/>, [20-01-2024]



LONDON STEREOSCOPIC COMPANY, La storia della moda, l'età vittoriana e i suoi merletti, DI MANUELE MENCONI PUBBLICATO: 29/11/2022, [online] harpersbazaar.com, available at: <https://www.harpersbazaar.com/it/moda/storie/a42061174/moda-eta-vittoriana/>, [20-01-2024]



Meet Lex Kilgour, DECEMBER 7, 2023, [online], canvasrebel available at: <https://canvasrebel.com/meet-lex-kilgour/>, [20-01-2024]



Georges-Pierre Seurat, "Una Domenica Pomeriggio sull'Isola della Grande-Jatte". Olio su tela (1884-86). The Art Institute, Chicago, [online] università degli studi di firenze, available at: <https://www.cssii.unifi.it/vp-73-eventi.html>, [20-01-2024]



Com'è nata e si è evoluta l'iconica giacca Bar di Dior, PUBBLICATO: 07/05/2021, [online] harpersbazaar.com, available at: <https://www.harpersbazaar.com/it/moda/tendenze/a36348952/dior-giacca-bar-storia/>, [20-1-2024]



Buyenlarge, STORIA DEL PUNTINISMO, LA TECNICA ARTISTICA PIÙ SCIENTIFICA DI SEMPRE, PUBBLICATO: 23/05/2022, [online] elle decor, available at: <https://www.elledecor.com/it/arte/a40076000/puntinismo-storia-corrente-protagonisti/>, [20-01-2024]

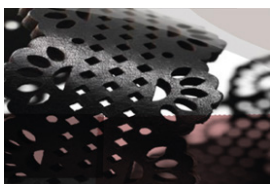

personal photo